

Building Regulations 1997

Technical Guidance Document J

Heat Producing Appliances

BAILE ÁTHA CLIATH
ARNA FHOILSIÚ AG OIFIG AN tSOLÁTHAIR

Le ceannach díreach ón
OIFIG DHÍOLTA FOILSEACHÁIN RIALTAIS,
TEACH SUN ALLIANCE, SRÁID THEACH LAIGHEAN, BAILE ÁTHA CLIATH 2.
nó tríd an bpost ó
FOILSEACHÁIN RIALTAIS, AN RANNOG POST-TRACHTA
51 FAICHE STIABHNA, BAILE ÁTHA CLIATH 2.
(Teil: 01-647 6000; Faics: 01-647 6843)
nó trí aon díoltóir leabhar

DUBLIN:
PUBLISHED BY THE STATIONERY OFFICE

To be purchased from the
GOVERNMENT PUBLICATIONS SALES OFFICE,
SUN ALLIANCE HOUSE, MOLESWORTH STREET, DUBLIN 2
or by mail order from
GOVERNMENT PUBLICATIONS, POSTAL TRADE SECTION,
51 ST. STEPHEN'S GREEN, DUBLIN 2
(Tel: 01-647 6000; Fax: 01-647 6843)
or through any bookseller

Price: €6.35



Amendments issued since publication

Technical Guidance Document J - Heat Producing Appliances

<i>Amd. No.</i>	<i>Text Affected</i>
J(i)	Transitional Arrangements:- Replace 1 January 1998 with 1 July 1998
J(ii)	2.18 : 4th line - Delete : “under a hearth”.
J(iii)	5.2 : Table 3 : replace titles in bold to read as follows - “ Location of tank ” “ Bund required ” “ Protection from fire in a building ” “ Protection from fire in relation to a boundary ”.
J(iv)	Reference to I.S. 51: 1983 in the following sections is hereby replaced by I.S. EN 1457: 1999 Class A1 N1 - Brick/Block chimneys. item 2.12(a) - Chimneys 3.11(a), and - Standards and other References.

Contents

	Page		Page
Introduction	2	Chimneys	12
Transitional Arrangements	2	Brick/block chimneys	12
The Guidance	2	Flue block chimneys	12
Existing Buildings	2	Wall thickness	12
Technical Specifications	2	Flexible flue liners	12
Materials and Workmanship	2	Debris collection space	13
Interpretation	2	Factory-made insulated chimneys	13
Part J : The Requirement	3	Hearths	13
Section 1	4	Shielding of appliances	13
General	4	Section 4	15
Air supply to appliances	4	ADDITIONAL PROVISIONS FOR OIL	
Air extract fans	4	BURNING APPLIANCES WITH A	
Flue pipes and chimneys	4	RATED OUTPUT UP TO 45 kW	
Tolerances	4	Air supply to appliances	15
Section 2	5	Flues	15
ADDITIONAL PROVISIONS FOR		Size	15
SOLID FUEL BURNING APPLIANCES		Direction	15
WITH A RATED OUTPUT UP TO 45 kW		Outlets	15
Air supply to appliances	5	Flue pipes and brick/blockwork chimneys	15
Flues	5	Factory-made insulated chimneys	15
Size	5	Hearths	16
Outlets	5	Shielding of appliances	16
Direction	7	Section 5	17
Flue pipes	7	OIL STORAGE TANKS	
Shielding	7	STANDARDS AND OTHER	
Chimneys	7	REFERENCES	19
Brick/block chimneys	7		
Refractory blockwork chimneys	8		
Wall thickness	8		
Combustible material	8		
Factory-made insulated chimneys	8		
Constructional hearths	8		
Fireplace recesses	9		
Walls adjacent to hearths	10		
Location of appliances	10		
Section 3	11		
ADDITIONAL PROVISIONS FOR			
INDIVIDUALLY FLUED (NON FAN-			
ASSISTED) GAS BURNING			
APPLIANCES WITH A RATED INPUT UP TO			
60 kW			
Solid fuel effect appliances	11		
Appliances in bathrooms and garages	11		
Air supply to appliances	11		
Flues	11		
Size	11		
Direction	12		
Outlets	12		
Flue pipes	12		
Shielding of flue pipes	12		

Building Regulations, 1997

Technical Guidance Document J

Heat Producing Appliances

Introduction

This document has been published by the Minister for the Environment under article 7 of the Building Regulations, 1997. It provides guidance in relation to Part J of the Second Schedule to the Regulations. The document should be read in conjunction with the Building Regulations, 1997, and other documents published under these Regulations.

In general, Building Regulations apply to the construction of new buildings and to extensions and material alterations to buildings. In addition, certain parts of the Regulations apply to existing buildings where a material change of use takes place. Otherwise, Building Regulations do not apply to buildings constructed prior to 1 June, 1992.

Transitional Arrangements

In general, this document applies to works, or buildings in which a material change of use takes place, where the works or the change of use commence or takes place, as the case may be on or after 1 July, 1998. Technical Guidance Document J - **Heat Producing Appliances**, dated 1991, also ceases to have effect from that date. However, the latter document may continue to be used in the case of works, or buildings in which a material change of use takes place -

- where the works or the change of use commence or takes place, as the case may be, before 1 July, 1998,
- in respect of which a Fire Safety Certificate under the Building Control Regulations, 1991 to 1994, has been granted, where the works or change of use commence or takes place, as the case may be, not later than 31 December, 2002.

The Guidance

The materials, methods of construction, standards and other specifications (including technical specifications) which are referred to in this document are those which are likely to be suitable for the purposes of the Regulations. Where works are carried out in accordance with the guidance in this document, this will, prima facie, indicate compliance with Part J of the Second Schedule to the Building Regulations. However, the adoption of an approach other than that outlined in the guidance is not precluded provided that the relevant requirements of the Regulations are complied with. Those involved in the design and construction of a building may be required by the relevant building control authority to provide such evidence as is necessary to establish that the requirements of the Building Regulations are being complied with.

Existing Buildings

In the case of material alterations or changes of use of existing buildings, the adoption without modification of the guidance in this document may not, in all circumstances, be appropriate. In particular, the adherence to guidance, including codes, standards or technical specifications, intended for application to new work may be unduly restrictive or impracticable. Buildings of architectural or historical interest are especially likely to give rise to such circumstances. In these situations, alternative approaches based on the principles contained in the document may be more relevant and should be considered.

Technical Specifications

Building Regulations are made for specific purposes, i.e. to secure the health, safety and welfare of persons, energy conservation and the special needs of disabled persons. Technical specifications (including harmonised European Standards, European Technical Approvals, National Standards and Agrément Certificates) are relevant to the extent that they relate to these considerations. Any reference to a technical specification is a reference to so much of the specification as is relevant in the context in which it arises. Technical specifications may also address other aspects not covered by the Regulations.

A reference to a technical specification is to the latest edition (including any amendments, supplements or addenda) current at the date of publication of this Technical Guidance Document. However, if this version of the technical specification is subsequently revised or updated by the issuing body, the new version may be used as a source of guidance provided that it continues to address the relevant requirements of the Regulations.

Materials and Workmanship

Under Part D of the Second Schedule to the Building Regulations, building work to which the Regulations apply must be carried out with proper materials and in a workmanlike manner. Guidance in relation to compliance with Part D is contained in Technical Guidance Document D.

Interpretation

In this document, a reference to a section, sub-section, part, paragraph or diagram is, unless otherwise stated, a reference to a section, sub-section, part, paragraph or diagram, as the case may be, of this document. A reference to another Technical Guidance Document is a reference to the latest edition of a document published by the Minister for the Environment under article 7 of the the Building Regulations, 1997. Diagrams are used in this document to illustrate particular aspects of construction - they may not show all the details of construction.

Heat Producing Appliances

Building Regulations - The Requirement

Part J of the Second Schedule to the Building Regulations, 1997, provides as follows:-

Air supply.	J1	A heat producing appliance shall be so installed that there is an adequate supply of air to it for combustion and for the efficient working of any flue pipe or chimney.
Discharge of products of combustion.	J2	A heat producing appliance shall have adequate provision for the discharge of the products of combustion to the outside air.
Protection of building.	J3	A heat producing appliance and any flue pipe shall be so designed and installed, and any fireplace and any chimney shall be so designed and constructed, as to reduce to a reasonable level the risk of the building catching fire in consequence of its use.
Oil storage tanks.	J4	A fixed oil storage tank which serves a heat producing appliance shall be so located as to reduce to a reasonable level the risk of fire spreading from a building to the tank.
Definition for this Part.	J5	In this Part, "heat producing appliance" means an appliance (including a cooker and an open fire) which is designed to burn solid fuel, oil or gas and includes an incinerator.

Section 1

General

1.1 In this Document, “non-combustible” means capable of being classified as non-combustible if subjected to the test for non-combustibility prescribed in BS 476: Fire tests on building materials and structures Part 4: 1970 (1984) Non-combustibility tests for materials.

Air Supply to Appliances

1.2 Each appliance should be:

- (a) room sealed, or
- (b) contained in a room or space which has a permanent ventilation opening. If this opening is to an adjoining room or space, then the adjoining room or space should have a permanent opening of the same size direct to external air.

Ventilation openings should not be provided in internal construction which is required to have fire resistance under the requirements of Part B of the Second Schedule to the Building Regulations. Ventilation openings provided in some external walls may also have to comply with these requirements.

Any appliance in a bath or shower room or a private garage must be of the room sealed type.

The definition of “ventilation opening” can be found in Technical Guidance Document F - Ventilation.

Air Extract Fans

1.3 If an air extract fan is fitted in a building containing a heat producing appliance (other than a room-sealed appliance), the appliance and flue should be able to operate effectively whether or not the fan is running. See also Technical Guidance Document F - Ventilation.

Flue Pipes and Chimneys

1.4 Unless an appliance is designed to operate without discharging the products of combustion to

the outside air, it should have a balanced or low level flue or be connected to a flue pipe or chimney which discharges to the external air.

1.5 Provision should be made to enable a flue to be inspected and cleaned. An opening should only be made into a flue for the purpose of:

- (a) inspection or cleaning, and an opening for this purpose should have a rigid, non-combustible and gastight cover, or
- (b) fitting an explosion door, draught stabilizer or draught diverter.

1.6 A flue should not open into more than one room or space except for the purpose of inspection or cleaning, but may serve more than one appliance in the same room.

Location of Appliances

1.7 Where a heat producing appliance is installed in a domestic or other garage, precautions should be taken to avoid impact damage to the appliance by a vehicle. Such precautions may consist of -

- (a) the provision of an adequate barrier around the appliance (see Technical Guidance Document - K for guidance on barriers), or
- (b) locating the appliance in a part of the garage where it cannot be struck by a vehicle.

Whatever precautions are taken, adequate space should be provided to allow the appliance to be properly maintained.

Tolerances

1.8 Reference should be made to Technical Guidance Document - D for guidance in relation to manufacturing and other tolerances applicable to building components generally.

Section 2

Additional Provisions for Solid Fuel Burning Appliances with a rated output up to 45 kW

2.1 Guidance on the installation of solid fuel burning appliances is contained in the following standards:

I.S. 258: Parts 1 and 2: 1984 Domestic Solid Fuel Cookers with Integral Boilers, Part 1 Safety Requirements, Part 2 General Requirements.

BS 8303 Part 1: 1994 Specification for design of installations, Part 2: 1994 Specification for installing and commissioning on site and Part 3: 1994 Recommendations for design and on site installation.

Air Supply to Appliances

2.2 Any room or space containing an appliance should have a ventilation opening (or openings) of at least the size shown in Table 1.

Flues

2.3 **Size** - Flue sizes should be at least:

- (a) for flue pipes, equal to that of the flue outlet on the appliance, or
- (b) for chimneys, at least the size shown in Table 2, but never less than the size of the flue outlet on the appliance or that recommended by the appliance manufacturer.

2.4 **Outlets** - The outlet from a flue should be positioned above the roof of a building as shown in Diagram 1.

Table 1 Air Supply to Appliances	
Solid fuel burning open appliance	A ventilation opening (or openings) with a total free area of at least 50% of the appliance throat opening area (of which at least 6500 mm ² is permanent ventilation) shall be provided. For description and dimensions of "throat", see BS 8303: Part 1:1994).
Other solid fuel appliance	A permanent air entry or opening with a total free area of at least 550 mm ² per kW of rated output above 5 kW shall be provided but in no case less than 6500 mm ² . Where a flue draught stabiliser is used the total free area should be increased by 300 mm ² for each kW of rated output.

Table 2 Size of Flues	
Installation	Minimum flue size
Fireplace recess with an opening up to 500 mm x 550 mm	194 mm diameter or square section of equivalent area.
Open fire	194 mm diameter or square section of equivalent area.
Fireplace recess with an opening in excess of 500 mm x 550 mm	a free area of 15% of the area of the recess opening
Closed appliance up to 20 kW rated output burning bituminous coal	150 mm diameter or square section of equivalent area
Closed appliance up to 20 kW rated output	125 mm diameter or square section of equivalent area
Closed appliance above 20 kW and up to 30 kW rated output	150 mm diameter or square section of equivalent area
Closed appliance above 30 kW and up to 45 kW rated output	175 mm diameter or square section of equivalent area
<i>Note:</i> Should an offset be necessary in a metal or similar flue of minimum dimensions serving a closed appliance, then the flue size should be increased by 25 mm on each dimension (diameter or each side of square flue).	

Outlet of a chimney or a flue pipe to be not less than 1 m above the highest point of contact of chimney and roof. Where the roof has a pitch of more than 10° on both sides and the outlet is at the ridge or within 600 mm of it, the height of the chimney or flue pipe may be reduced to 600 mm

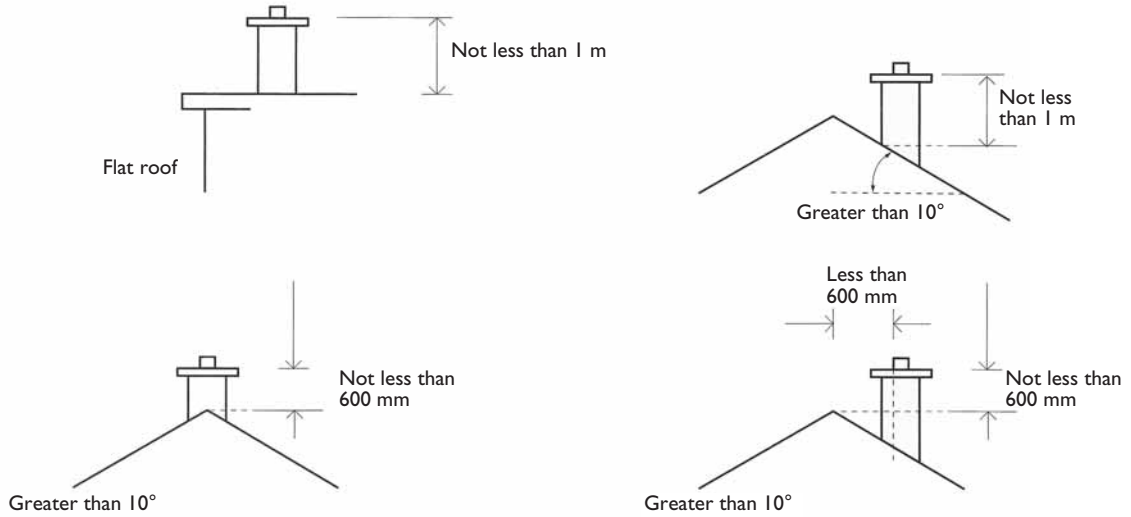

(a) HEIGHT OF FLUE OVER ROOF

The outlet of a chimney or flue pipe should also be not less than 1 m above the top of any opening skylight, opening window or wall ventilator within 2.3 m

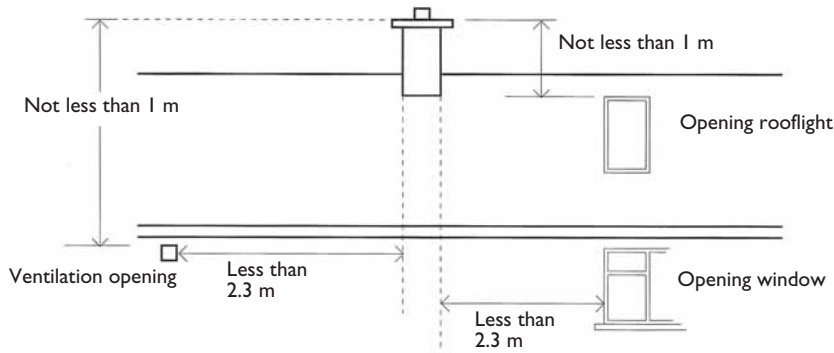

(b) HEIGHT OF FLUE OVER OPENINGS

The outlet of a chimney or a flue pipe in relation to adjacent or adjoining buildings should be as shown below.

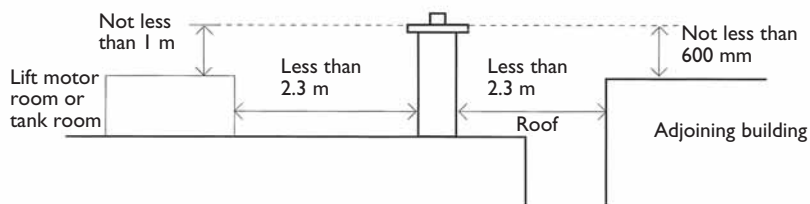

(c) HEIGHT OF FLUE OVER ADJACENT OR ADJOINING BUILDING

2.5 Direction - Flues should be vertical wherever possible and where a bend is necessary, it should not make an angle of more than 37.5° with the vertical. Horizontal flue runs should be avoided except in the case of a back outlet appliance, when the length of the horizontal section should not exceed 150 mm.

Flue Pipes

2.6 A flue pipe should only be used to connect an appliance to a chimney and should not pass through any roof space.

2.7 Flue pipes may be of any of the following materials:

- (a) cast iron as described in BS 41: 1973 (1981), or
- (b) mild steel with a wall thickness of at least 3 mm, or
- (c) stainless steel with a wall thickness of at least 1 mm and as described in BS 1449: Part 2: 1983 Specification for stainless and heat resisting steel plate, sheet and strip, for Grade 316 S11, 316 S13, 316 S16, 316 S31, 316 S33, or the equivalent Euronorm 88-71 designation, or
- (d) vitreous enamelled steel complying with BS 6999: 1989.

2.8 Flue pipes with spigot and socket joints should be fitted with the socket uppermost.

2.9 Shielding - Flue pipes should be separated from combustible material by at least the distances shown in Diagram 2.

Chimneys

2.10 Chimneys for use with solid fuel appliances should be capable of withstanding a temperature of 1100°C without any structural change which would impair the stability or performance of the chimney.

Diagram 2 Separating flue-pipe from surface of adjacent combustible material Par. 2.9

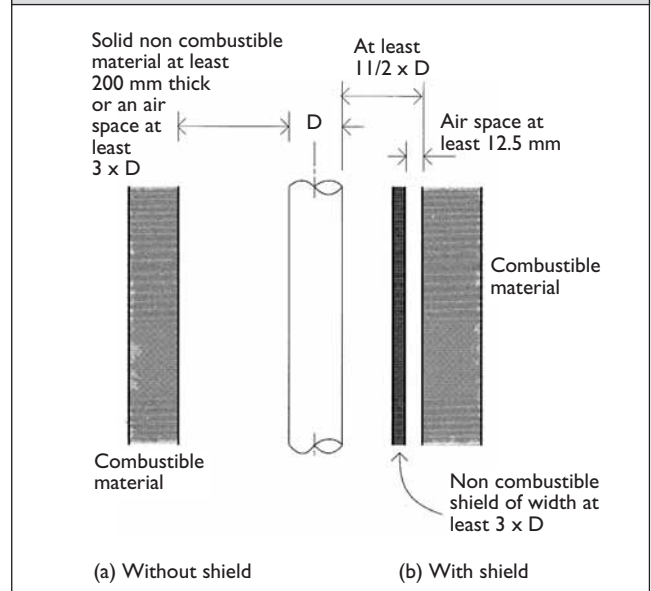

2.11 Where a chimney is not directly over an appliance, a debris collecting space should be provided which is accessible for emptying.

Brick/block chimneys

2.12 Brick/block chimneys should be lined with:

- (a) clay flue liners with rebated or socketed joints as described in I.S. EN 1457: 1999 Class A1 N1, or
- (b) imperforate clay pipes with socketed joints as described in I.S./EN 295-1: 1992 Vitrified Clay Pipes and Fittings and Pipe Joints for Drains and Sewers, or
- (c) high alumina cement and kiln burnt or pumice aggregate pipes with rebated or socketed joints or steel collars around joints.

The linings should be fitted with the sockets or rebates uppermost. Liners should be jointed with fire-proof mortar, and any space between the liners and the brickwork should be filled with weak 1:1:12 cement/lime/sand mortar or insulating concrete.

2.13 Refractory blockwork chimneys - These are chimneys constructed of purpose made blocks which may incorporate a flue or be lined. They should be made of refractory material, or a combination of high alumina cement and kiln burnt or pumice aggregates, or lined as in par. 2.12.

2.14 Wall thickness - The thickness of the walls of a brick or blockwork chimney, excluding the thickness of any liner should be at least:

- (a) 100 mm thick between one flue and another,
- (b) 100 mm thick between a flue and the outside air or between a flue and another part of the same building (but not another part which is a dwelling or is constructed as a separate fire compartment),
- (c) 200 mm thick between a flue and another compartment of the same building, another building or another dwelling. This thickness should be carried up to the underside of the roof covering,
- (d) 200 mm thick between one flue and another where flues serve appliances located in separate compartments, buildings, or dwellings. This thickness should be carried up to the underside of the roof covering.

2.15 Combustible material - Combustible material should be separated from a brick or blockwork chimney by at least the following distance:

- (a) 200 mm from a flue, or
- (b) 40 mm from the outer surface of a brick or blockwork chimney or fireplace recess unless it is a floorboard, skirting, dado or picture rail, mantelshelf or architrave. Metal fixings in contact with combustible materials should be at least 50 mm from a flue.

Factory-Made Insulated Chimneys

2.16 Factory-made insulated chimneys should be:

- (a) constructed and tested to meet the relevant recommendations given in BS 4543 Factory-made insulated chimneys Part 1, and
- (b) installed in accordance with the manufacturers' instructions or to meet the relevant recommendations of BS 7566 Installation of factory made chimneys to BS 4543 for domestic applications, Parts 1 - 4 1992.

2.17 A factory-made insulated chimney should not:

- (a) pass through any part of the building forming a separate compartment, unless it is cased in non-combustible material giving at least half the fire resistance of the compartment wall or floor (see Technical Guidance Document B - Fire Safety).
- (b) be placed with its outer wall nearer to combustible material than a distance x , or
- (c) pass through a cupboard, storage space or roof space, unless it is surrounded by a non-combustible guard at a distance of at least x from the outer wall of the chimney.

For (b) and (c) above, the distance x is to be found by test in accordance with BS 4543 Part 1: 1990, which may be found in the manufacturers' instructions.

Constructional Hearths

2.18 A constructional hearth should be provided of solid, non-combustible material at least 125 mm thick (which may include the thickness of any solid, non-combustible floor) and at least the sizes shown in Diagram 3.

2.19 Combustible material should not be placed under a constructional hearth unless:

- (a) it is to support the edges of the hearth, or

Diagram 3 Hearth sizes Par. 2.18

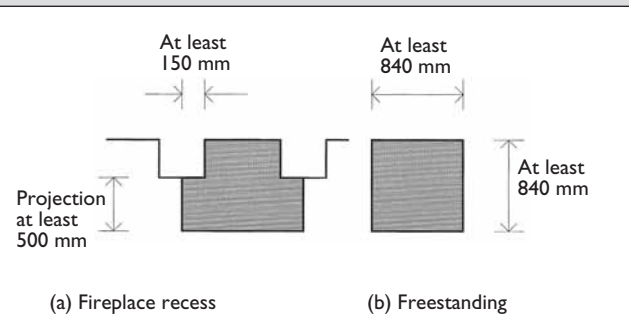

- (b) there is an air space of at least 50 mm between the material and the underside of the hearth, or there is a distance of at least 250 mm between the material and the top of the hearth (see Diagram 4).

Diagram 4 Combustible material Par. 2.19
under hearth

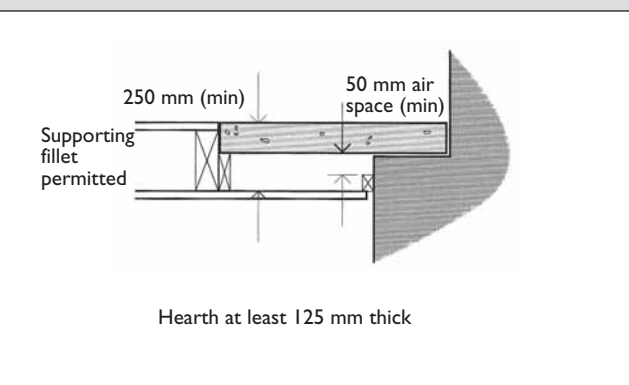

Fireplace Recesses

2.20 Fireplace recesses should be constructed of solid non-combustible material to the appropriate size given in Diagram 5.

Diagram 5 Fireplace recesses Par. 2.20

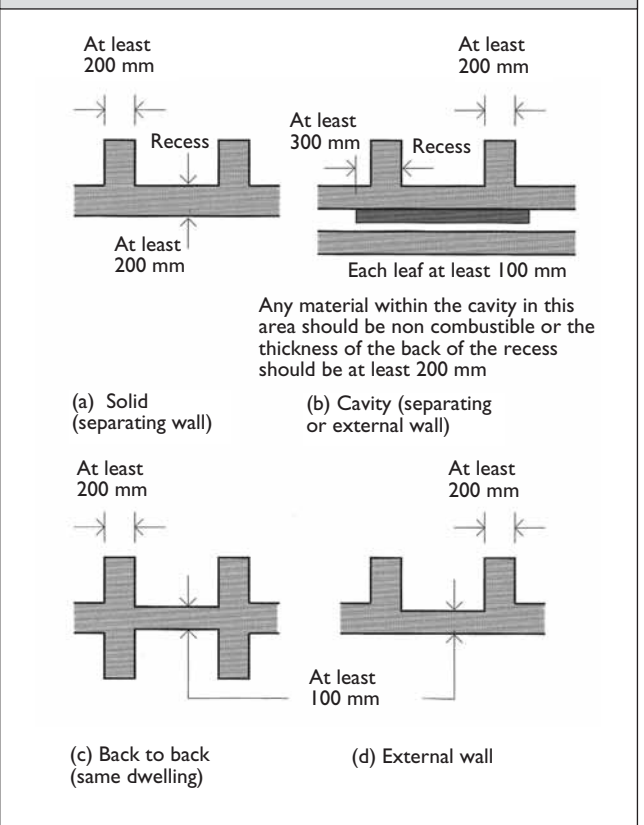

Walls adjacent to Hearths

2.21 Walls which do not form part of a fireplace recess should be constructed as indicated in Diagram 6.

Diagram 6 **Wall adjacent to hearth** Par. 2.21

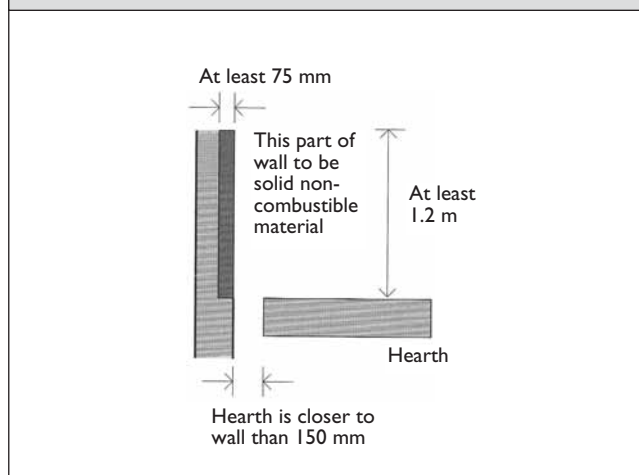

Location of Appliances

2.22 An appliance:

- should not be placed closer to the edges of a constructional hearth or to any combustible material laid on it, than is shown in Diagram 7, and
- should be separated from combustible materials as shown in Diagram 8.

Diagram 7 **Placing appliance on constructional hearth** Par. 2.22

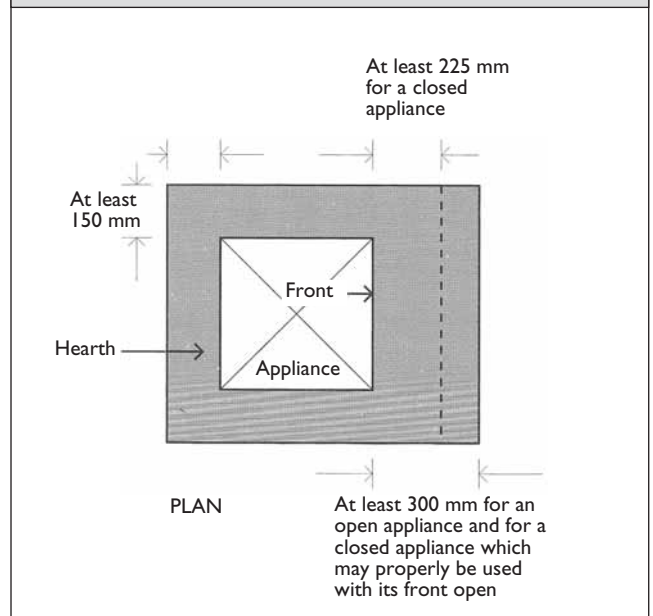
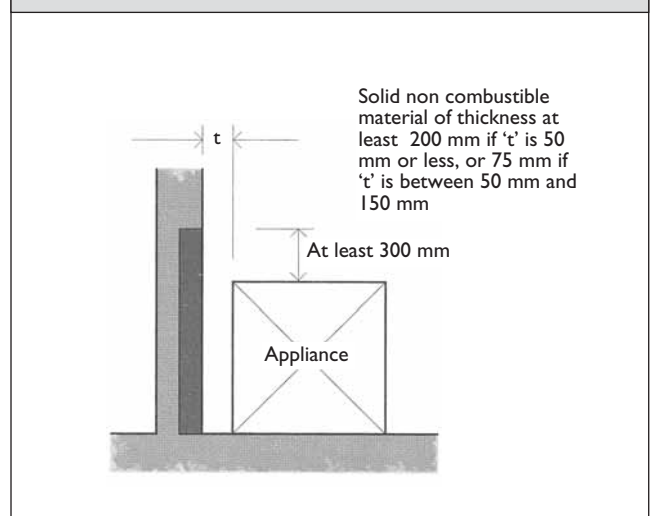

Diagram 8 **Separating appliance from combustible materials in walls** Par. 2.22



Section 3

Additional Provisions for Individually Flued (Non-Fan Assisted) Gas Burning Appliances with a Rated Input up to 60 kW and for Gas Burning Cooking Appliances

3.1 Guidance on the installation of gas burning appliances is contained in the following standards and codes of practice:

I.S. 283 : 1987

I.S. 284 : 1987

I.S. 285 : 1987

I.S. 286 : 1987

I.S. 813 : 1996

BS 5546 : 1990

BS 5864 : 1989

BS 6173 : 1990

Solid Fuel Effect Appliances

3.2 These appliances simulate the burning of coal and wood with a live flame. Installation should be in accordance with the relevant recommendations of I.S. 813 : 1996.

Appliances in Bathrooms and Garages

3.3 Any appliance in a bath or shower room or a private garage must be of the room-sealed type.

Air Supply to Appliances

(other than for balanced flued or solid fuel effect appliances)

3.4 Any room or space containing a cooker should have an openable window or other means of providing ventilation. If the room or space has a volume less than 10 m³, then, in addition, a permanent ventilation opening of at least 5000 mm² should be provided.

3.5 Any room or space containing an open-flued appliance should have a permanent ventilation opening of at least 450 mm² for each kW of appliance input rating, but in no case less than 6500 mm².

Flues

3.6 Size (other than for balanced flued or solid fuel effect appliances) - The flue size should be at least that stated below:

- (a) in the case of a gas fire, a cross-section area of at least 12000 mm² if the flue is round, or 16500 mm² if the flue is rectangular, and have a minimum dimension of 90 mm, or
- (b) for any other appliance, a cross-sectional area of at least that of the outlet from the appliance.

3.7 Direction (other than balanced flues) - Horizontal flue runs should be avoided except in the case of a back outlet appliance, when the length of the horizontal section should not exceed 700 mm. If a bend is necessary in a flue, it should not make an angle of more than 37.5° with the vertical.

3.8 Outlets - The outlet from a balanced-flued appliance should be:

- (a) so situated externally as to allow free intake of air and dispersal of products of combustion, and
- (b) at least 600 mm from any opening into the building which is wholly or partly above the terminal, and
- (c) protected with a guard if persons could come into contact with the terminal or if it could be subject to damage, and
- (d) designed so as to prevent the entry of any matter which might restrict the flue.

The outlet from any other appliance should be:

- (a) so situated at roof level, that air may pass freely across it at all times, and
- (b) at least 600 mm from any opening into the building, and

-
- (c) fitted with a flue terminal if the flue outlet is less than 175 mm measured across the axis of the flue. This does not apply to a gas fire.

Flue Pipes

3.9 Materials - Flue pipes may be of any of the following materials:

- (a) sheet metal as described in BS 715: 1993, or
- (b) asbestos cement as described in BS 567: 1973 (1989), or
- (c) cast iron as described in BS 41: 1973 (1981), or
- (d) any material described in Section 2 for a solid fuel appliance, or
- (e) any other material fit for its intended purpose.

Flue pipes with spigot and socket joints should be fitted with the sockets uppermost.

3.10 Shielding - Flue pipes should:

- (a) be at least 25 mm from any combustible material, or
- (b) where passing through a wall, floor or roof, be separated from any combustible material by a non-combustible sleeve enclosing an air space of at least 25 mm around the flue pipe, or
- (c) where passing through a compartment wall or a compartment floor, be cased with non-combustible material with at least half the fire resistance needed for the wall or floor (see Technical Guidance Document B - Fire Safety).

For a double-walled flue pipe, the 25 mm distance may be measured from the outside of the inner pipe.

Chimneys

3.11 Brick/block chimneys - Brick/block chimneys should be lined with:

- (a) clay flue liners with rebated or socketed joints as described in I.S. EN 1457: 1999 Class A1 N1, or
- (b) imperforate clay flue pipes as described in I.S./EN 295-1: 1992, or
- (c) any material described in Section 2 for a solid fuel appliance.

Linings should be fitted with the sockets or rebates uppermost to prevent condensation running out and to prevent any caulking material from being adversely affected. Joints between the liners and brickwork should be filled with weak sand/lime mortar or insulating concrete.

3.12 Flue block chimneys - Flue blocks should be as described in BS 1289: Flue blocks and masonry terminals for gas appliances: Part 1: 1986 and Part 2: 1989.

3.13 Wall thickness - The wall thickness of a brick or blockwork chimney should be at least 25 mm. Any chimney wall which:

- (a) is part of the wall of a compartment of the same building, another building or another dwelling, should give at least the fire resistance needed for the compartment or separating wall (see Technical Guidance Document B - Fire Safety), or
- (b) passes through a compartment wall or a compartment floor, should have at least half the fire resistance needed for the compartment wall or floor (see Technical Guidance Document B - Fire Safety). If the compartment wall or floor is masonry material, it may also form the chimney wall.

3.14 Flexible flue liners - A flexible flue liner may be used in a chimney if:

- (a) the liner complies with the requirements of BS 715: 1993, and
- (b) the chimney -
 - (i) was built before the coming into operation of Building Regulations, or

-
- (ii) is already lined or constructed of flue blocks as recommended in this Technical Guidance Document.

3.15 Debris collection space - If the chimney is not lined or not constructed of flue blocks as recommended in this Document, then a debris collection space should be provided at the bottom of the chimney with a volume of at least 0.012 m³ and a depth of at least 250 mm below the point of connection of the appliance with the chimney. The space should be readily accessible for clearance of debris, for example by removal of the appliance.

Factory-made insulated Chimneys

3.16 Any factory-made insulated chimney should be as described in Sections 2 or 4.

Hearths

(other than for solid fuel effect appliances)

3.17 A hearth should always be provided for an appliance unless:

- (a) every part of any flame or incandescent material in the appliance will be at least 225 mm above the floor, or
- (b) the appliance complies with the recommendations of the appropriate parts of the following standards:

I.S. 280: 1986;

I.S. 281: 1986;

I.S. 282: 1987:

I.S. 285: 1987

I.S. 803: 1987;

I.S. 805: 1987;

BS 5258: 1986; or

BS 5386.

3.18 In case of a back boiler, the hearth should be constructed:

- (a) of solid, non-combustible material at least:
 - (i) 125 mm thick, or
 - (ii) 25 mm thick placed on non-combustible supports at least 25 mm high, and
- (b) to the size given in Diagram 9.

3.19 In the case of any other appliance, the hearth should be constructed of solid, non-combustible material at least 12 mm thick and to the size given in Diagram 9.

Shielding of Appliances

3.20 Unless the appliance complies with the relevant recommendations of the appropriate parts of I.S. 644: 1983 and I.S. 645: 1983 and the standards listed in par. 3.17(b), the backs, tops and sides of appliances and any draught-diverters should be separated from any combustible material by either (a) a shield of non-combustible material at least 25 mm thick, or (b) an air space of at least 75 mm (see Diagram 10).

Diagram 9 **Hearth size** *Pars. 3.18*

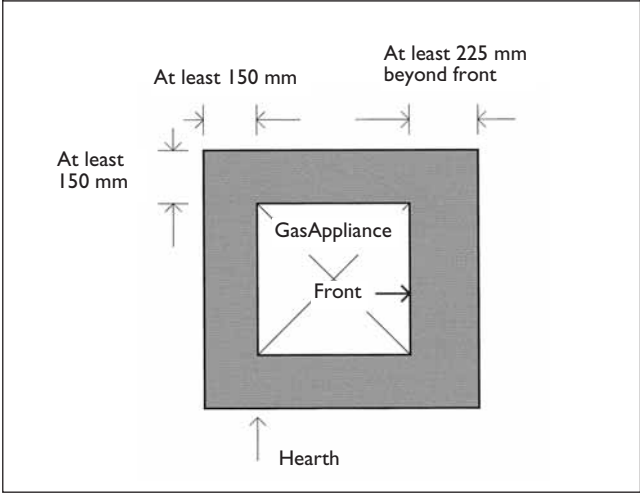
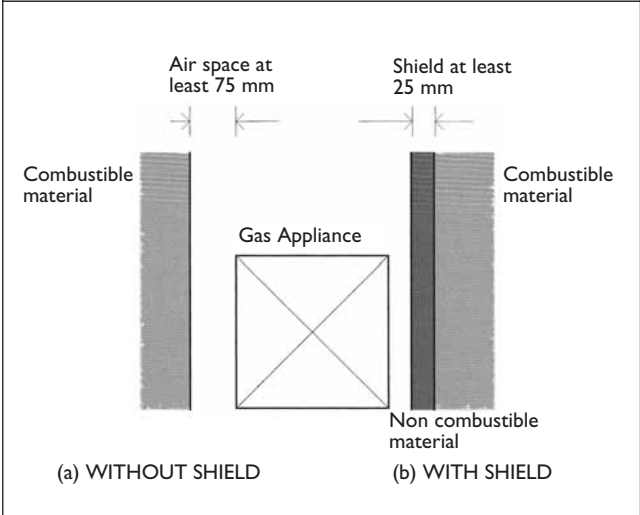

Diagram 10 **Separating appliance from combustible material** *Par. 3.20*



Section 4

Additional Provisions for Oil Burning Appliances with a Rated Output up to 45 kW

Guidance on the installation of oil burning appliances is contained in:

BS 5410 : Part 1 : 1977.

Air Supply to Appliances

4.1 Any room or space containing an appliance (other than a balanced-flued appliance) should have a permanent ventilation opening of free area at least 550 mm² for each kW of rated output above 5 kW, but in no case less than 6500 mm².

Flues

4.2 Size (other than for balanced and low level flues) - The flue size should be at least:

- (a) for a flue pipe, the same as for the flue outlet from the appliance,
- (b) for a chimney, 100 mm diameter for appliances with a rated output up to 20 kW; 125 mm diameter for appliances with a rated output between 20 kW and 32 kW; 150 mm diameter for appliances with a rated output between 32 kW and 45 kW. If the flue is of square section, then it should have a cross-sectional area equivalent to the corresponding circular chimney.

4.3 Direction (other than for balanced or low level flues) - Horizontal flue runs should be avoided, and if a bend is required in a flue, it should not make an angle of more than 45° with the vertical.

4.4 Outlets - The outlet from a balanced flue or low level discharge appliance should be:

- (a) so situated externally as to allow the dispersal of the products of combustion and, with a balanced flue, the free intake of air, and
- (b) at least 600 mm from any opening into the building, and

- (c) protected with a terminal guard if persons could come into contact with it or if it could be subject to damage, and
- (d) designed so as to prevent the entry of any matter which might restrict the flue.

The outlet from a flue serving a pressure jet appliance may be terminated anywhere above the roof line. The outlet from a flue serving any other appliance should be positioned above the roof line as shown in Diagram 1.

Flue Pipes and Brick/Block Chimneys

4.5 The provision for flue pipes and brick and blockwork chimneys will depend on the temperature of the flue gases under the worst operating conditions. If this temperature:

- (a) is likely to exceed 260°C, then the provisions of pars. 2.6 to 2.9 and 2.10 to 2.14 should be applied where relevant, or
- (b) is unlikely to exceed 260°C, the provisions of pars. 3.9 to 3.15 should be applied where relevant.

Factory-made insulated Chimneys

4.6 Factory-made insulated chimneys should be:

- (a) constructed and tested to meet the relevant recommendations given in BS 4543 Part 1: and Part 3: 1990, and
- (b) installed so as to meet the requirements of BS 7566 : 1992.

4.7 An insulated metal chimney should not:

- (a) pass through a part of the building forming a separate compartment, unless it is cased in non-combustible material giving at least half the fire resistance of the compartment wall or floor (see Technical Guidance Document B - Fire Safety), or

-
- (b) be placed with its outer wall nearer to combustible material than a distance x , or
 - (c) pass through a cupboard, storage space or roof space, unless it is cased in a non-combustible material at a distance of at least x from the outer wall of the chimney.

For (b) and (c) above, the distance x is to be found by test in accordance with BS 4543 : Part 1 : 1990 which may be found in the manufacturers' instructions.

Hearths

4.8 If the surface temperature of the floor below the appliance is:

- (a) likely to exceed 100°C , then a constructional hearth should be provided as described in pars. 2.18 and 2.19, or
- (b) unlikely to exceed 100°C , the appliance may stand on a rigid, imperforate sheet of non-combustible material without a constructional hearth.

4.9 Shielding of appliances - If the surface temperature of the sides and back of an appliance is likely to exceed 100°C , the appliance should be shielded as described in par. 3.20.

Section 5

Oil Storage Tanks

Introduction

5.1 This section deals with the location of an oil storage tank serving a heat producing appliance in a building and the fuel feed system from the tank to the appliance. Where a fire occurs in a building, depending on the location of the oil storage tank, there is a risk of fire spread to the tank and to the fuel. An oil storage tank could also be exposed to sources of fire from outside the boundaries of the site of the building. This section makes provisions to minimise to a reasonable level the risk of such fire spread.

Oil storage tank with a capacity not exceeding 3500 litres

5.2 An oil storage tank with a capacity not exceeding 3500 litres should be located in accordance with Table 3 below.

For the purpose of Table 3, the following terms apply:

Bund - a catchpit beneath the tank, without a drain, constructed with non-combustible materials and capable of containing the contents of the tank, plus an additional 10%.

Chamber - a fully enclosed ventilated space, bounded by non-combustible 60 minutes fire resisting construction (see Technical Guidance Document B), including a self closing fire door wholly above the bund level.

Barrier - means a wall or screen having not less than 30 minutes fire resistance (see Technical Guidance Document B) and extending at least 300 mm above and beyond the ends of the tank.

Location of tank	Bund required	Protection from fire in a building	Protection from fire in relation to a boundary
Within a building	yes	within a chamber	Not applicable
External, above ground	yes (see note 1 below)	in accordance with sub-section 5.3	760 mm from boundary or barrier provided
External, wholly below ground	no	no requirement	no requirement

Note 1. An oil storage tank not exceeding 2500 litres capacity which serves a dwelling house does not require a bund. An oil storage tank which is not provided with a bund should be installed on or above a non combustible base which extends out at least 300 mm from all sides of the tank.

Protection of an external above ground tank from fire in a building

5.3 An oil storage tank should be located so as to minimise the possible exposure of the tank from a fire in the building. Protection of the tank is generally achieved by locating the tank so as to achieve a minimum separation distance from the building or by the provision of non-combustible fire resisting barriers (see Technical Guidance Document B) or screen walls between the tank and the building. An external wall of a building may be considered as a barrier or screen wall where it meets the non combustibility and fire resistance requirements. In these situations, particular care should be taken in relation to unprotected openings such as doors and windows and the proximity of combustible building elements, such as overhead roof eaves.

Guidance on minimum separation distances from buildings and boundaries for oil storage tanks is given in BS 5410: Part 1: 1977 (currently under revision), together with guidance on protection measures, including the provision of screen walls, where such distances are reduced. BS 5410: Part 1: 1977 refers to tanks which comply with specific standards. The revised standard will extend the range of tank types covered by the guidance and, when published, may be used for this purpose. Where a tank is used which is not covered by the guidance in BS 5410: Part 1, the protective measures should be appropriate to the level of risk of fire spread to the tank.

The oil feed installation from the oil storage tank to the appliance should conform with the recommendations contained in BS 5410: Part 1, including the fitting of an automatic fuel cut-off valve.

Oil storage tank with a capacity which exceeds 3500 litres

5.4 The location of an oil storage tank with a capacity which exceeds 3500 litres should be in accordance with the requirements of BS 5410: Part 2: 1978 or BS 5410: Part 3: 1976, as appropriate.

Standards and other references

ICP 4: 1989 Non-Domestic Installations for Manufactured and Natural Gas (Edition 2)

I.S. 258: Parts 1 and 2: 1984 Domestic Solid Fuel Cookers with Integral Boilers, Part 1: Safety Requirements; Part 2: General Requirements Amd No 1: 1986

I.S. 280: Parts 1 and 2 : 1986 Combined Appliances Gas Fire/Back Boiler Part 1 Essential Safety Requirements. Part 2 Design, Construction and Performance Amd No 1: 1989

I.S. 281: Parts 1 and 2 : 1986 Gas Fired Central Heating Boilers and Circulators Part 1 Essential Safety Requirements. Part 2, Design, Construction and Performance Amd No 1: 1989

I.S. 282: Parts 1 and 2 : 1987 Gas Fires Part 1 Essential Safety Requirements Part 2 Design, Construction and Performance Amd No 1: 1989

I.S. 283: Parts 1 and 2 : 1987 Flueless Space Heaters (excluding Catalytic Combustion Heaters) using Third Family Gases

I.S. 284: Parts 1 and 2 : 1987 Flueless Catalytic Heaters Using Third Family Gases

I.S. 285: Parts 1 and 2 : 1987 Decorative Gas Log and Other Fuel Effect Appliances for 2nd and 3rd family gases Part 1 Essential Safety Requirements Part 2 Design, Construction and Performance Amd No 1: 1989

I.S. 286: 1987 Safety of Flueless Gas Fired Space Heaters first and second Family Gases (excluding Catalytic Combustion Devices)

I.S. 288: 1987 Thermal Performance Requirements for Water Heaters and Space Heaters

I.S. 644: 1983 Domestic Cooking Appliances Burning Gas

I.S. 645: 1983 Gas Burning Appliances for Instantaneous Production of Hot Water for Domestic Use

I.S. 803: Parts 1 and 2 : 1987 Gas-Fired Fanned-Circulation Ducted-Air Heaters Amd No 1: 1989

I.S. 805: Parts 1 and 2 : 1987 Gas Fired Storage Water Heaters Amd No 1: 1989

I.S. 813: 1996 Domestic Gas Installations

I.S./EN 295-1: 1992 Vitrified Clay Pipes and Fittings and Pipe Joints for Drains and Sewers Part 1 Requirements

I.S./EN 295-2: 1992 Vitrified Clay Pipes and Fittings and Pipe Joints for Drains and Sewers Part 2 Quality Control and Sampling

I.S./EN 295-3: 1992 Vitrified Clay Pipes and Fittings and Pipe Joints for Drains and Sewers Part 3 Test Methods

I.S. EN 1457: 1999 Class A1 NI Clay Flue Linings and Flue Terminals

BS 41: 1973 (1981) Specification for cast iron spigot and socket flue or smoke pipes and fittings

BS 476: Fire tests on building materials and structures Part 4: 1970 (1984) Non-combustibility tests for materials AMD 2483 and AMD 4390

BS 567: 1973 (1989): Specification for asbestos-cement flue pipes and fittings, light quality AMD 5963

BS 715: 1993: Specification for metal flue pipes, fittings, terminals and accessories for gas-fired appliances with a rated input not exceeding 60 kW

BS 835: 1973 (1989) Specification for asbestos-cement flue pipes and fittings, heavy quality AMD 5964

BS 1289: Flue blocks and masonry terminals for gas appliances Part 1: 1986 Specification for precast concrete flue blocks and terminals

BS 1289: Flue blocks and masonry terminals for gas appliances Part 2: 1989 Specification for clay flue blocks and terminals

BS 1449: Steel plate, sheet and strip Part 2: 1983 Specification for stainless and heat-resisting steel plate, sheet and strip AMD 4807; AMD 6646; AMD 8828

BS 4543: Factory-made insulated chimneys Part 1: 1990 Methods of test AMD 8379

BS 4543: Factory-made insulated chimneys Part 2: 1990 Specification for chimneys with stainless steel flue linings for use with solid fuel fired appliances AMD 8380

BS 4543: Factory-made insulated chimneys Part 3: 1990 Specification for chimneys with stainless steel flue lining for oil fired appliances AMD 8381

BS 5258: Safety of domestic gas appliances, Part 1: 1986 Specification for central heating boilers and circulators

BS 5258: Safety of domestic gas appliances Part 4: 1987 Specification for fanned-circulation ducted-air heaters

BS 5258: Safety of domestic gas appliances, Part 5: 1989 Specification for gas fires

BS 5258: Safety of domestic gas appliances, Part 7: 1977 Storage water heaters

BS 5258: Safety of domestic gas appliances, Part 8: 1980 Combined appliances: gas fire/back boiler

BS 5258: Safety of domestic gas appliances, Part 12: 1990 Specification for decorative fuel effect gas appliances (2nd and 3rd family gases) AMD 7507

BS 5258: Safety of domestic gas appliances, Part 13: 1986 Specification for convector heaters

BS 5386: Specification for gas burning appliances, Part 1: 1976 Gas burning appliances for instantaneous production of hot water for domestic use, AMD 2990; AMD 5832; AMD 6940 Part 4: 1983 Built-in domestic cooking appliances

BS 5386 Specification for gas burning appliances Part 2: 1981 (1986) Mini water heaters (2nd and 3rd family gases)

BS 5386 Specification for gas burning appliances Part 3: 1980 Domestic cooking appliances burning gas AMD 4162; AMD 4405; AMD 4878; AMD 5220; AMD 6642; AMD 6883

BS 5410: Code of practice for oil firing: Part 1: 1977 Installations up to 44 kW output capacity for space heating and hot water supply purposes, AMD 3637

BS 5546: 1990 Specification for installation of gas hot water supplies for domestic purposes (1st, 2nd and 3rd family gases) AMD 6656; AMD 8129

BS 5864: 1989: Specification for installation in domestic premises of gas-fired ducted-air heaters of rated input not exceeding 60 kW AMD 8130

BS 6173: 1990 Specification for installation of gas-fired catering appliances for use in all types of catering establishments (1st, 2nd and 3rd family gases)

BS 6461: Installation of chimneys and flues for domestic appliances burning solid fuel (including wood and peat), Part 1: 1984 Code of practice for masonry chimneys and flue pipes AMD 5649

BS 6999: 1989 (1996) Specification for vitreous-enamelled low-carbon-steel flue pipes, other components and accessories for solid-fuel-burning appliances with a rated output of 45 kW AMD 8949

BS 7435: Fibre cement flue pipes, fittings and terminals Part 1: 1991 Specification for light quality fibre cement flue pipes, fittings and terminals

BS 7566: Installation of factory-made chimneys to BS 4543 for domestic appliances Part 1: 1992 Method of specifying installation design information

BS 7566: Installation of factory-made chimneys to BS 4543 for domestic appliances Part 2: 1992 Specification for installation design

BS 7566: Installation of factory-made chimneys to BS 4543 for domestic appliances Part 3: 1992 Specification for site installation

BS 7566: Installation of factory-made chimneys to BS 4543 for domestic appliances Part 4: 1992 Recommendations for installation design and installation

BS 8303: Code of practice for installation of domestic heating and cooking appliances burning solid mineral fuels Part 1: 1994 Specification for the design of installations

BS 8303: Code of practice for installation of domestic heating and cooking appliances burning solid mineral fuels Part 2: 1994 Specification for installing and commissioning on site

BS 8303: Code of practice for installation of domestic heating and cooking appliances burning solid mineral fuels Part 3: 1994 Recommendations for design and on site installation

BS EN 625: 1996 Gas-fired central heating boilers - specific requirements for the domestic hot water operation of combination boilers of nominal heat input not exceed 70 kW